

TAKSTAR® 得胜



SC系列 | 无线麦克风
Wireless Microphone

尊敬的用户：

感谢您选购得胜SC系列无线麦克风，为了您能够更好的了解使用本产品，建议您在使用前仔细阅读本说明书。

若存在有疑问或者您有宝贵的建议，可通过拨打得胜官方服务热线400 6828 333或微信扫描二维码关注得胜官方公众号与我们联系。



■ 产品特性

SC-4R四通道无线接收主机

- 采用UHF宽频段设计，预编程400个可选信道，可多套同时叠机使用
- 采用D-PLL射频频率锁定技术，频率精准、工作稳定可靠
- 采用二次变频接收技术，抗干扰能力强，无线距离可达50米
- 采用专业音频压缩-扩展技术，噪音小，尾音小，动态范围大
- 采用智能微电脑控制，可配置4路无线话筒同时工作
- MIC/LINE切换选择，可根据现场扩声条件，快速进行设置
- 配置4路独立卡依音频输出，Type-C接口输出，方便设备连接
- 6.3mm级联输出/输入，可实现多台设备级联输出，灵活配置
- 监听输出，可自由调整输出音量大小，满足不同使用需求

SC-2R双通道无线接收主机

- 采用UHF宽频段设计，预编程400个可选信道，可多套同时叠机使用
- 采用D-PLL射频频率锁定技术，频率精准、工作稳定可靠
- 采用二次变频接收技术，抗干扰能力强，无线距离可达50米
- 采用专业音频压缩-扩展技术，噪音小，尾音小，动态范围大
- 采用智能微电脑控制，可配置2路无线话筒同时工作
- MIC/LINE切换选择，可根据现场扩声条件，快速进行设置
- 配置2路独立卡依音频输出，Type-C接口输出，方便设备连接
- 6.3mm级联输出/输入，可实现多台设备级联输出，灵活配置
- 监听输出，可自由调整输出音量大小，满足不同使用需求

SC-TD无线手持麦克风

- 采用UHF频段设计，避开工业频率干扰
- 宽频率设计，提供400个频道选择，无线距离可达50米
- 采用D-PLL射频频率锁定技术，频率精准、工作稳定可靠
- 专业音频压缩-扩展技术，噪音小、尾音小、动态范围大
- LCD显示屏设计，可显示电池、频道等信息，使用户实时掌握机器状态
- 采用1.5V (AA) 电池供电，电池使用时间长，维护、更换方便

SC-TL无线腰挂发射器

- 采用UHF频段设计，避开工业频率干扰
- 宽频率设计，提供400个频道选择，无线距离可达50米
- 采用高性能拾音器，拾音距离远，说话轻松、清晰自然
- 设有低切功能，有效减少环境噪音或舞台震动带来的影响
- 低电提醒设计，在低电时，提醒用户更换电池，杜绝使用中途断电
- LCD显示屏设计，可显示电池、频道等信息，使用户实时掌握机器状态
- 采用1.5V (AA) 电池供电，电池使用时间长，维护、更换方便

SC-TW无线会议麦克风

- 采用UHF频段设计，避开工业频率干扰
- 宽频率设计，提供400个频道选择，无线距离可达50米
- 高性能拾音器，拾音距离远，说话轻松、清晰自然
- 低切功能设计，有效减少环境噪音或桌面震动带来的影响
- 具有增益功能调节，可根据现场环境灵活设置
- 支持无线充电/Type-C有线充电两种形式，可边充边用
- 触摸式发言开关，消除传统开关带来的机械噪声

TW-C无线充电器

- 具有无线充电功能，提供安全、高效的无线充电
- 充电器具有两个充电区域，可同时充电使用
- Type-C充电接口，支持市面主流供电电压供电输入（5V/2A，5V/3A，9V/2A）及以上适配器
- 支持为SC-TW以及兼容无线充电功能的手机和移动设备充电

■ 产品配置

SC-4R

- SC-4R接收机……………1台
- 音频传输线……………1条
- 电源适配器……………1个
- 天线……………4支
- 角码……………1套
- 说明书……………1份

SC-2R

- SC-2R接收机……………1台
- 音频传输线……………1条
- 电源适配器……………1个
- 天线……………2支
- 角码……………1套
- 说明书……………1份

SC-TD (选配)

- 手持麦克风……………1支
- 碱性电池……………2节 (AA)

SC-TW (选配)

- 无线会议麦克风……………1个
- Type-C电源线……………1条 (1.5m)

TW-C (选配)

- TW-C充电器……………1个
- Type-C电源线……………1条 (1.5m)

SC-TL (选配)

- 腰挂发射器……………1个
- 头戴麦克风……………1个
- 领夹麦克风……………1个
- 碱性电池……………2节 (AA)

■ 技术参数

SC-4R四通道无线接收主机/SC-2R双通道无线接收主机

- 频率范围：640~690 Mhz（分段设计）
- 调制方式：宽带FM
- 可调范围：50MHz
- 信道数：400
- 信道间隔：250KHz
- 静音控制：导频ID码
- 频率稳定度：±0.015%
- 动态范围：≥100dB A+
- 调制频偏：±48KHz
- 音频响应：60Hz~18KHz
- 综合信噪比：≥100dB A+
- 综合失真：≤0.5%（at 1KHz）
- 音频输出方式：独立平衡和混合
6.3mm及3.5mm耳机插座
- 音频最大输出电平：1.4V/RMS
（at 1KHz THD=1%）
- 使用距离：50米（空旷地带）
- 天线接口：TNC（50欧阻抗）
- 灵敏度：-103±3dBm
- 工作温度：-20℃~+50℃

SC-TL 无线腰挂发射器

- 频率范围：640~690 MHz（分段设计）
- 发射功率：≤10mW
- 2次谐波：≥-40dBc
- 频率稳定度：±0.015%
- 杂散抑制：≥50dB
- 供电方式：2节AA电池
- 接口方式：3.5mm插座自锁
- 使用时间：约8小时（视电池容量大小而有所差异）
- 腰挂发射机尺寸(L*W*H)：79*32*15.5mm
- 腰挂发射机重量：约100g

SC-TW 无线会议麦克风

- 频率范围：640~690 MHz（分段设计）
- 发射功率：≤10mW
- 杂散抑制：≥50dB
- 2次谐波：≥-40dBc
- 频率稳定度：±0.015%
- 电池容量：1000mAh 3.7Wh
- 拾音距离：≤50cm
- 使用时间：约8小时
- 麦克风尺寸(L*W*H)：129*101*325mm
- 麦克风重量：约625g
- 充电时间：约3小时
- 充电模式：5V-12V有线充，10W无线充

■ 技术参数

SC-TD 无线手持麦克风

- 频率范围：640~690 Mhz（分段设计）
- 发射机供电：2节AA电池
- 发射机功率：≤10mW
- 2次谐波：≥-40dBc
- 频率稳定度：±0.015%
- 使用时间：约8小时（视电池容量大小而有所差异）
- 手持麦克风尺寸（D*H）：53mm*270 mm
- 手持麦克风重量：约350g

注：以上数据由得胜实验室测试得到。

TW-C 无线充电器

- 供电输入：双充支持 5V/2A，5V/3A，9V/2A等以上功率主流适配器，单充支持至少5V/1A
- 输出功率：5W以上
- 感应距离：5mm以内

■ 功能示意

接收机正面板

- ① 功能按键：用于通道选择、频率调整、对频、扫频等工作
- ② 液晶显示：显示对频工作状态、频率、接收信号电平等信息
- ③ IR红外对频窗口：配合“SYNC”键，将频率参数传至发射机
- ④ 电源开关：控制机内电源供应

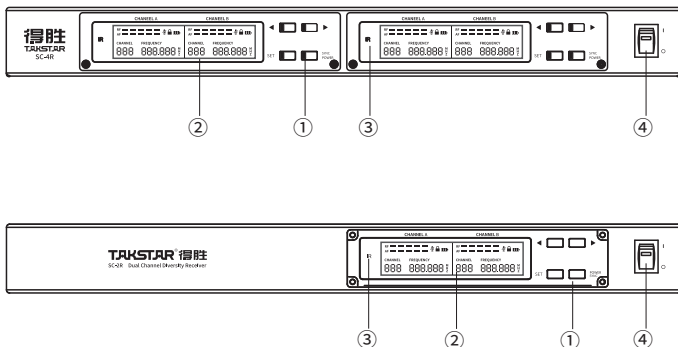

接收机背面板

- ① 电源插座：连接DC 12V电源至输入插座；插座的中心电极连接正电压
- ② 天线连接座：连接外置天线，增加使用距离
- ③ 音频平衡输出：采用“XLR”型插座，提供各通道独立信号输出
- ④ 耳机接口：用于连接耳机设备进行监听
- ⑤ 音量调节：调整输出音量大小，顺时针旋转为增大音量，逆时针旋转为减小音量
- ⑥ 混合输入/输出：用于级联多台设备
- ⑦ USB接口：可通过Type-C数据线提供声卡输出等
- ⑧ 增益选择开关：用于调节“MIC”与“LINE”输出

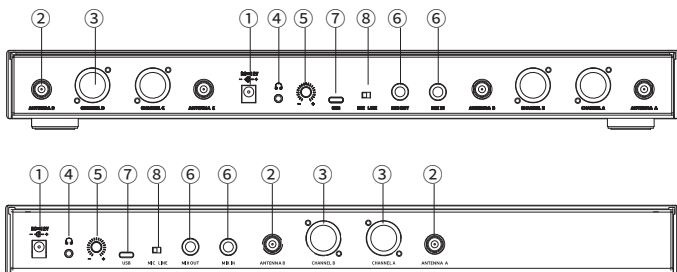

SC-TD手持麦克风

- ① 网头及音头模组：网头用以保护将声音转换成电信号的音头模组，并能防止麦克风放置在台面时滚动
- ② 液晶显示器：显示工作频率、电池电量等信息
- ③ 电源开关：用于开启/关闭发射机电源
- ④ 麦克风管体：管端装配网头、音头模组、管体内装电池、发射电路板、尾部内置发射天线
- ⑤ IR对频窗口：配合接收机“SET”键，将频率参数传至发射器；(红外窗口在尾管内部)
- ⑥ 电池仓：用于装入AA电池2节；（注意电池放置的极性）

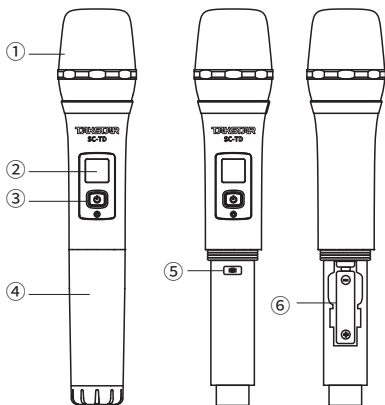

SC-TL腰挂发射器

- ① 显示屏：显示工作频率、电池电量等信息
- ② “SET”键：长按SET键开启增益调节模式，停止操作2秒后，自动关闭调节模式；建议头戴麦克风增益档位为4，领夹麦克风增益档位为8
- ③ “+”增加键：在增益调节模式下，短按对应增加MIC增益
- ④ “-”减小键：在增益调节模式下，短按对应减小MIC增益
- ⑤ 电源开关键：长按两秒开关机，循环点开开启或关闭静音功能
- ⑥ 电池仓：用于安装5号电池
- ⑦ 低切开关：拨到“ON”位置，可衰减150Hz以下的低频环境噪声（如交通声、空调声、震动声等），拨到“OFF”恢复正常拾音
- ⑧ 静音指示灯：关闭静音时，常亮绿灯，开启静音时，常亮红灯
- ⑨ 背扣：用于将发射器扣于腰带或裤腰上使用
- ⑩ 麦克风插座：用于连接3.5mm接口的麦克风
- ⑪ 外置天线：1/4波长长天线，增强信号发射距离
- ⑫ IR对频窗口：对频时发射红外对频信号

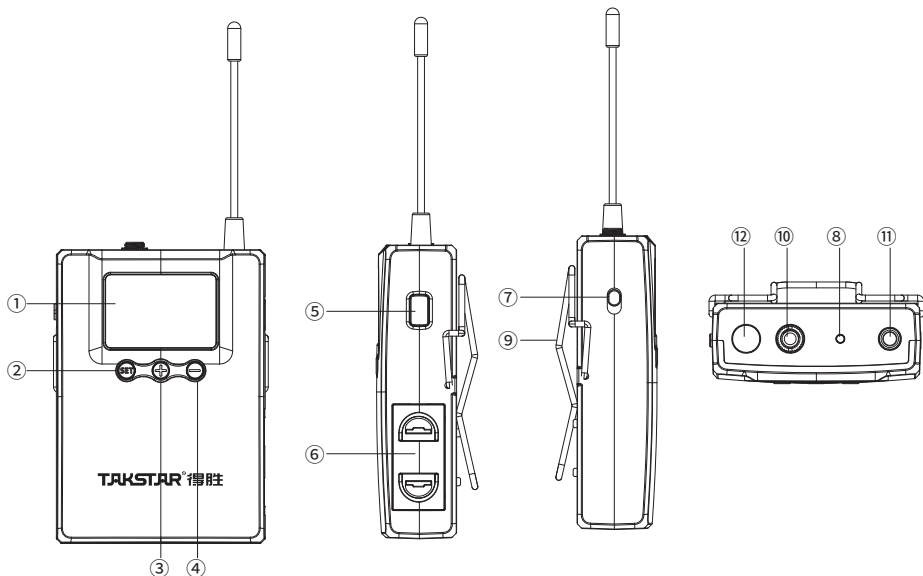

发射器显示屏

- ①低切功能：开启低切时显示，关闭低切时消失
- ②工作频率：显示当前发射器工作频率
- ③电池电量：以电量格数多少来表示当前发射器电池电量，电量严重不足时，电池符号闪烁
- ④静音显示：开启静音时显示，关闭静音时消失
- ⑤麦克风声音动态：跟随麦克风声音信号大小动态变化

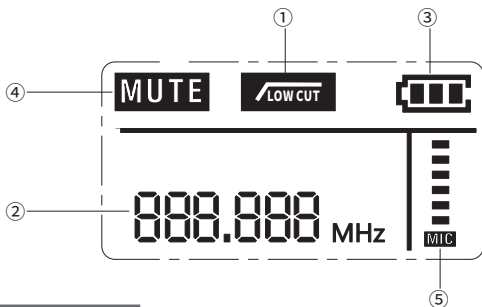

SC-TW无线会议麦克风

- ① 电源开关：长按2秒开启/关闭麦克风
- ② 静音指示灯：指示灯长亮蓝灯为拾音状态，指示灯熄灭为静音状态
- ③ 静音开关：通过触摸开关实现拾音及静音状态之间循环切换。触摸静音开关，指示灯长亮蓝灯，为拾音状态；再次触摸静音开关，指示灯熄灭，为静音状态
- ④ 充电接口：通过Type-C充电线为麦克风供电
- ⑤ IR对频窗口：在需要对频操作时，将此窗口对准接收机的IR位置进行
- ⑥ 低切开关：当开关拨至“0”位置时，为正常拾音状态；当开关拨至“80”位置时，可滤除80Hz以下的低频环境噪音（如呼吸声及喷麦声等）；当开关拨至“150”位置时，可滤除150Hz以下的低频环境噪声（如交通声、空调系统、震动声等）
- ⑦ 高低功率切换键：用于切换高低发射功率
- ⑧ 增益开关：手动增益调节，可根据现场灵活配置：当拾取的音源信号太强时，可以拨到“-10dB”位置，能够衰减信号，避免输出信号失真；在大部分的拾音应用场景，推荐拨到“0”位置；当拾取音源距离较远或音源信号较弱时，拨到“+10dB”位置，可以增强信号，拾音更清晰。

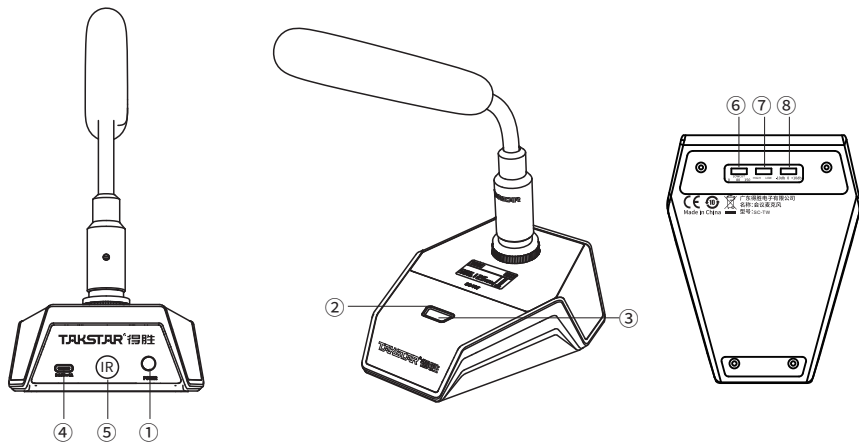

TW-C 无线充电器

- ① 充电接口：通过Type-C充电线为无线充电器供电
- ② 可充电区域：将无线麦克风底座放置该区域即可进行充电
- ③ 指示灯：无线充电器通电状态下，指示灯显示白灯；放置麦克风进行充电状态下，指示灯蓝灯呼吸。

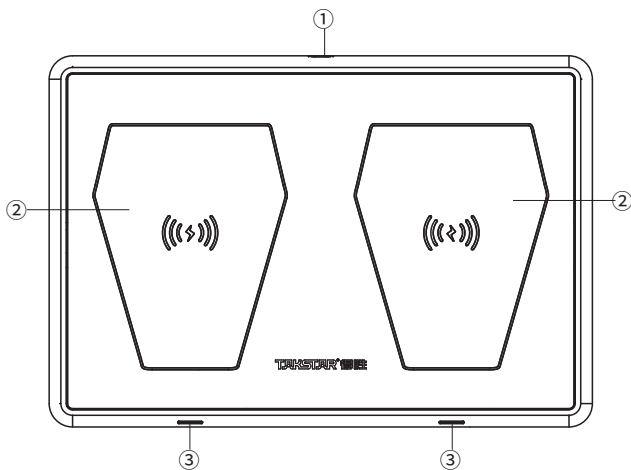

■ 使用说明

SC-2R/4R接收机使用说明

1. 手动频率调节：

点按“SET”键，待调整通道的显示屏闪烁，点击“<”或“>”调整所需通道，点按“SET”键，所选通道频率显示闪烁，“<”或“>”调整所需频道/频率；当已调整到需要使用的频率时，点按“SYNC”键，再打开发射机电源，将发射机上的红外接收窗口“IR”与接收机上的红外发射窗口成直线相对(对频距离可选择在10cm-30cm之间)，待发射器显示频率跟接收机的频率一样时，则对频成功；如对频失败，则点按“SET”键或无操作8秒后退出。

2. 自动扫频操作：

点按“set”键，待调整通道的显示屏闪烁，点击“<”或“>”调整所需通道，长按“SYNC”键2秒，接收机的对应通道进入自动扫描状态，频率会跳动，当扫描到干净频点时，接收机会自动发出红外对频状态，如下图。这时打开发射机电源，将发射机上的红外接收窗口“IR”对准接收机上的“IR”红外发射窗口即可。

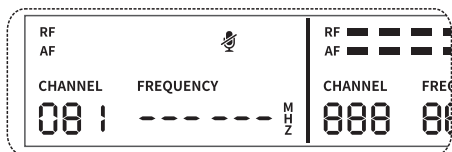

(注意：在多套使用时，前面对上频率的需打开发射机，在对下一套接收机进行自动扫描)

3. 音量调节：

点按“SET”键，待调整通道的显示屏闪烁，点击“<”或“>”调整所需通道，长按“<”或“>”2秒进入音量调节，然后点按“<”“>”调整所需音量（分九档1-9）；

4. 系统锁定操作：

锁定：在图①初始界面下长按“SET”键2秒显示图②界面，所有功能键将被锁定（电源开关键除外）
解锁：长按“SET”键2秒，显示图③界面可解锁。

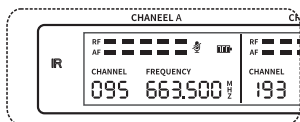

①

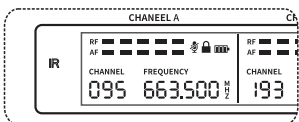

②

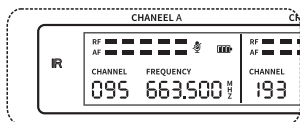

③

SC-TD手持麦克风使用说明

1. 将两节5号电池按正确的方向装到支架内，长按电源键约2秒，LCD显示屏亮，开机完成，如下图；LCD屏同时显示当前工作频道、电池电量。
2. 若需更改工作频道，应首先改变接收机频道，然后将发射机的IR对频窗口和接收机上的红外对频窗口对准，并按接收机面板上的“SYNC”键可将新的频道参数传至发射机（请参考接收机频率调节）。
3. 需要关闭麦克风时，在开机的状态下，长按电源键约2秒LCD显示“OFF”然后显示屏不亮，关机完成。

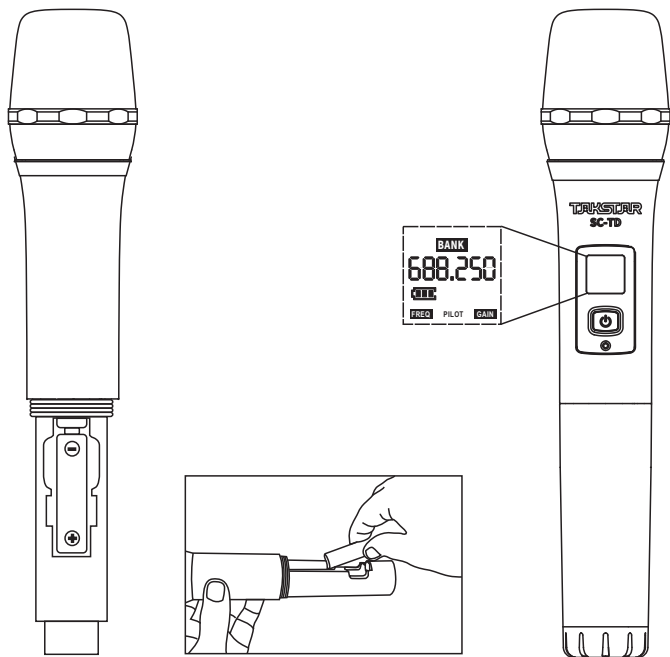

SC-TL腰挂发射器使用说明

1. 安装电池：同时按压电池仓伸缩键取出电池仓；将2节5号电池按电池仓标明的正负极性安装，注意电池极性不要装反；将电池仓推送入发射器电池卡座内，直到电池仓伸缩键“哒”的一声扣紧到位；如下图A：
2. 将头戴麦克风或夹领麦克风插头插入发射器的“MIC”插座，并锁紧固定；如下图B：
3. 开机前，先将接收机音量调小，然后按接收机电源按钮开接收机，电源导通后，液晶显示器背景灯亮，所有字符全部显示，随后主显示栏显示接收机频道、频率、自动对频状态；
4. 观察接收器液晶显示屏的RF和AF电平表，若有强的干扰，应调换频道避开干扰点；
5. 长按2秒发射器电源开关键，发射器开机，接收机对应频道的RF电平表信号强度点亮；
6. 若需更改工作频道，应首先改变接收机频道，然后将发射机的IR对频窗口和接收机上的红外对频窗口对准，并按接收机面板上的“SYNC”键可将新的频道参数传至发射机（请参考接收机频率调节）；
7. 根据实际情况，适当的调节接收器的麦克风输出音量大小。

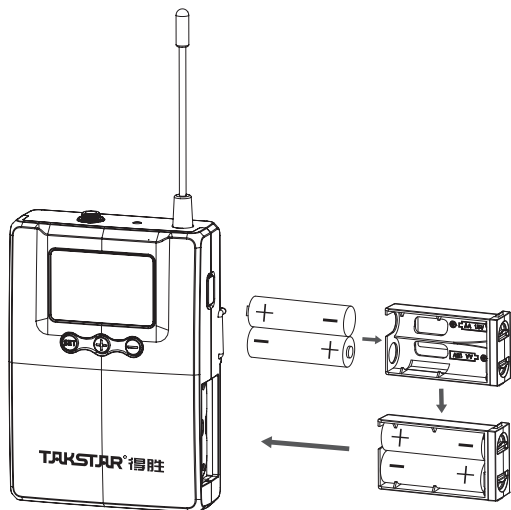

图A

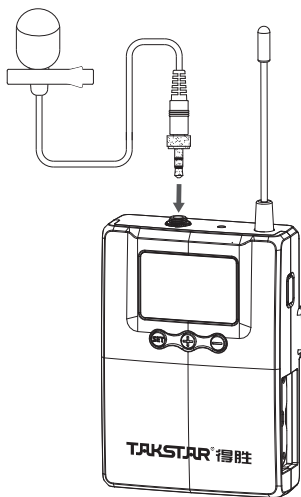

图B

SC-TW无线会议麦克风使用说明

1. 长按电源开关2秒，开启麦克风；
2. 若需更改工作频道，应首先改变接收机频道，然后将发射机的IR对频窗口和接收机上的红外对频窗口对准，并按接收机面板上的“SYNC”键可将新的频道参数传至发射机（请参考接收机频率调节）；
3. 触摸静音开关，指示灯长亮蓝灯，则麦克风为拾音状态；
4. 建议说话时，应与会议麦克风保持在20-50cm左右。

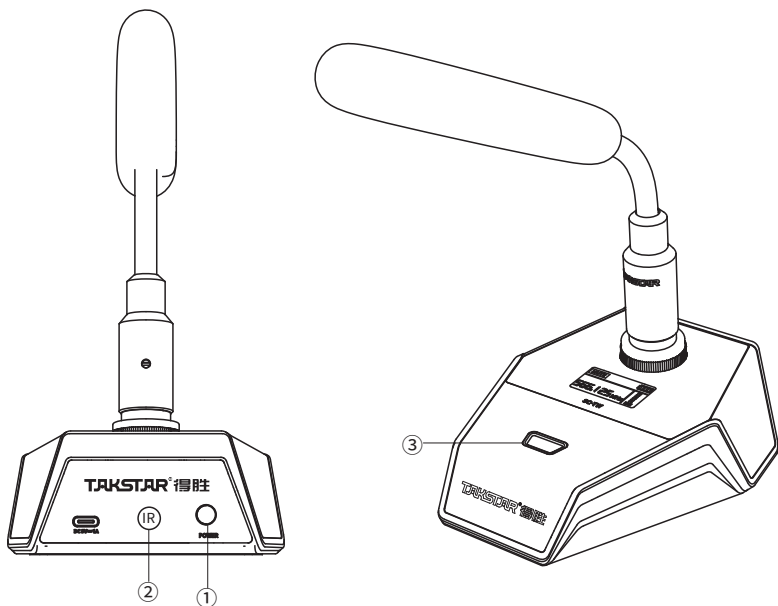

TW-C充电器使用说明

1. 将无线充电器的USB线连接至已插入交流电源插座的普通兼容充电器，或适用的USB电源。
 2. 确保无线充电器朝上且充电器上面没有任何物品。
 3. 将无线会议麦克风置于无线充电器的可充电区域，此时指示灯蓝灯闪烁，表示正在充电中。
- 注：若无线会议麦克风未正确摆放，可能导致麦克风无法正常充电。

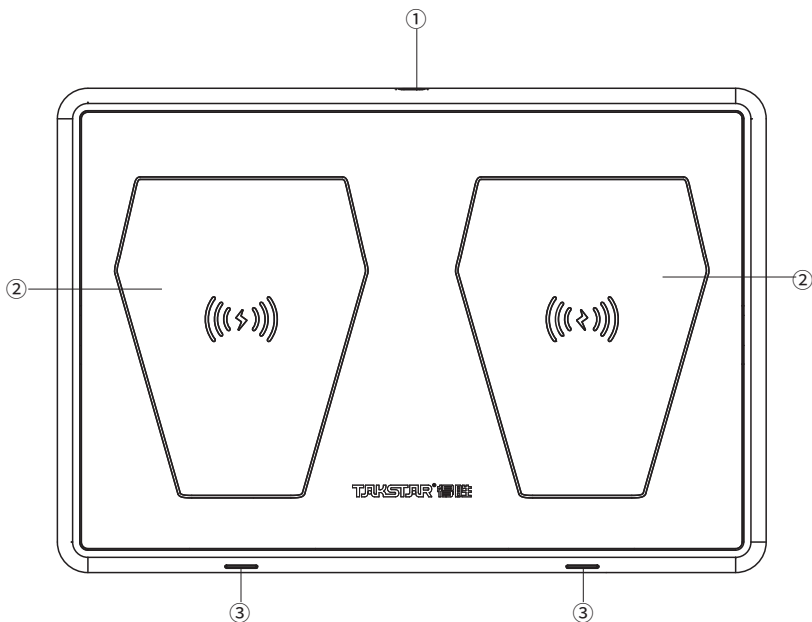

■ 故障排除

故障现象	故障原因
发射器、接收机无指示	发射器电池耗尽，接收机电源未接好
接收机无射频信号	收发不同频或超出接收范围
有射频信号，但无音频信号	发射器处于静音状态
音频信号背景噪声太大	接收输出电平低，有干扰信号或接收机未装天线，信噪比下降
音频信号失真	发射器调制频偏过大，或接收机输出电平过高
使用距离较短，信号不稳定	接收机天线安装不当，周围有强电磁干扰

■ 安全警示

为避免电击、高温、着火、辐射、爆炸、机械危险以及使用不当等可能造成的人身伤害或财产损失，使用本产品前，请仔细阅读并遵守以下事项：

1. 使用产品时请确认所连接设备与本产品功率是否匹配以及合理调整音量大小，不要在超过产品功率及大音量下长时间使用，以免造成产品异常和耳朵听力损伤；
2. 使用中若发现有异常（如冒烟、异味等），请立即关闭电源开关并拔掉电源插头，然后将产品送经销商检修；
3. 若产品需要使用可拆装电池时，严禁使用外壳绝缘材料破损的电池，请不要为非充电电池充电；
4. 废弃电池需放入指定的分类垃圾桶，不可作为儿童玩具或直接丢弃，以免造成安全隐患或影响环境；
5. 本产品及配件都应放置在室内干燥通风处，勿长期存放在潮湿、灰尘多的环境，使用中避免靠近裸露火源、碰到液体物质、雨淋、产品进水、过度碰撞、抛掷、振动本机及覆盖通风孔，以免损坏其功能；
6. 若产品需要固定于墙壁或天花板上时，请确保固定到位，防止因固定强度不足导致产品发生跌落危险；
7. 使用该产品时需遵守相关安全规定，法律法规明确禁止使用场合请勿使用本机，以免导致意外事故；
8. 请不要自行拆机改装或维修，以防止出现人身伤害，如有问题或服务需求请联系当地经销商跟进处理。

■ 关于图标含义解释



此符号表示，根据WEEE指令(2012/19/EU)和国家法律，由于这种类型的废弃物会有潜在的有害物质，可能对环境 and 人类健康产生负面影响，所以本产品不应与您的家庭垃圾一起处置，应将本产品交由授权的电气和电子设备（WEEE）回收站回收。同时，您在正确处理本产品的同时将有助于自然资源的有效利用。如需了解更多有关您可以在何处放置废物回收设备的信息，请联系您当地的城市办事处、废物管理局或家庭废物处理服务部门。

■ 关于本说明书

本说明书中内容符合截止印刷之日的技术规格。由于得胜公司会不断改进产品，本说明书可能不符合您的特定产品的技术规格。要获取最新版说明书，请访问得胜官网，然后下载说明书文件。技术规格、设备或另售的附件在各个地区可能有所不同，如有问题请与当地得胜经销商确认。如需更多支持和深层产品信息，请浏览得胜官方网站：<https://www.takstar.com/>

■ Preface

Dear Customer,

Thank you for purchasing Takstar SC Series Wireless Microphone. In order to better understand and use the product, please read this manual carefully.

If you have any questions or suggestions, please contact our local dealer.

■ Features

SC-4R Four-Channel Wireless Receiver

- UHF broadband design, pre-programmed with 400 optional channels, usable simultaneously in multiple sets.
- D-PLL RF frequency lock technology for accurate frequency and stable performance.
- Dual-conversion receiving technology for strong anti-interference capability and transmission up to 50m.
- Pro audio companding technology for low noise & tail sound and large dynamic range.
- Intelligent microcomputer control enables 4 wireless microphones to work simultaneously.
- MIC/LINE switching option adapts to different on-site requirements for sound reinforcement.
- 4 independent XLR audio outputs and 1 Type-C output for convenient connection.
- 6.3mm cascade output/input, configurable for multi-device cascaded output.
- Monitor output with adjustable volume for different usage scenarios.

SC-2R Dual-Channel Wireless Receiver

- UHF broadband design, pre-programmed with 400 optional channels, usable simultaneously in multiple sets.
- D-PLL RF frequency lock technology for accurate frequency and stable performance.
- Dual-conversion receiving technology for strong anti-interference capability and transmission up to 50m.
- Pro audio companding technology for low noise & tail sound and large dynamic range.
- Intelligent microcomputer control enables 2 wireless microphones to work simultaneously.
- MIC/LINE switching option adapts to different on-site requirements for sound reinforcement.
- 2 independent XLR audio outputs and 1 Type-C output for convenient connection.
- 6.3mm cascade output/input, configurable for multi-device cascaded output.
- Monitor output with adjustable volume for different usage scenarios.

SC-TD Wireless Handheld Microphone

- UHF band design, avoiding industrial frequency interference.
- Wide frequency design, 400 selectable channels, wireless transmission up to 50 meters.
- D-PLL RF frequency lock technology for accurate frequency and stable performance.
- Pro audio companding technology for low noise & tail sound and large dynamic range.
- Intuitive LCD display presents real-time device info such as battery and channel status.
- Powered by 2pcs 1.5V AA batteries, long battery life, easy to maintain and replace.

SC-TL Wireless Bodypack Transmitter

- UHF band design, avoiding industrial frequency interference.
- Wide frequency design, 400 selectable channels, wireless transmission up to 50 meters.
- High performance pickup, capturing sound clearly, naturally and effortlessly at distance.
- Low-cut function, effectively reducing the impact of environmental noise or stage vibration.
- Low battery reminder notifies users to replace battery in time; no more sudden power outage.
- Intuitive LCD display presents real-time device info such as battery and channel status.
- Powered by 2pcs 1.5V AA batteries, long battery life, easy to maintain and replace.

SC-TW Wireless Conference Microphone

- UHF band design, avoiding industrial frequency interference.
- Wide frequency design, 400 selectable channels, wireless transmission up to 50 meters.
- High performance pickup, capturing sound clearly, naturally and effortlessly at distance.
- Low-cut function, effectively reducing the impact of environmental noise or desk vibration.
- Gain control, adaptable to different on-site requirements.
- Wireless charging/Type-C wired charging supported; use while charging.
- Capacitive mute control, eliminating mechanical noise from conventional switch.

TW-C Wireless Charger

- Designed with safe and efficient wireless charging function.
- Charger with two charging areas enables two-device simultaneous charging.
- Universal Type-C charging interface, supports mainstream power adapters (5V 2A/5V 3A/9V 2A or above).
- Supports charging for SC-TW and other smartphones/mobile devices with wireless charging function.

■ Package Contents

SC-4R

- SC-4R Receiver ······ 1 pc
- Audio Cable ······ 1 pc
- Power Adapter ······ 1 pc
- Antenna ······ 4 pcs
- Angle Bracket ······ 1 set
- User Manual ······ 1 pc

SC-TD (Optional)

- Handheld Microphone ······ 1 pc
- Alkaline AA Battery ······ 2 pcs

SC-TL (Optional)

- Bodypack Transmitter ······ 1 pc
- Headset Microphone ······ 1 pc
- Lavalier Microphone ······ 1 pc
- Alkaline AA Battery ······ 2 pcs

SC-TW (Optional)

- Wireless Conference Microphone ······ 1 pc
- 1.5m Type-C Power Cable ······ 1 pc

TW-C (Optional)

- TW-C Charger ······ 1 pc
- 1.5m Type-C Power Cable ······ 1 pc

SC-2R

- SC-2R Receiver ······ 1 pc
- Audio Cable ······ 1 pc
- Power Adapter ······ 1 pc
- Antenna ······ 2 pcs
- Angle Bracket ······ 1 set
- User Manual ······ 1 pc

■ Specifications

SC-4R Four-Channel Wireless Receiver/SC-2R Dual-Channel Wireless Receiver

- Frequency Range: 640~690 MHz (segmented)
- Modulation: broadband FM
- Adjustable Range: 50MHz
- Number of Channels: 400
- Channel Spacing: 250KHz
- Squelch Control: pilot ID code
- Frequency Stability: $\pm 0.015\%$
- Dynamic Range: $\geq 100\text{dB A+}$
- Frequency Deviation: $\pm 48\text{KHz}$
- Audio Response: 60Hz~18KHz
- Overall S/N Ratio: $\geq 100\text{dB A+}$
- Overall Distortion: $\leq 0.5\%$ (at 1KHz)
- Audio Output: discrete bal and combo 6.3mm & 3.5mm headphone jack
- Audio Max Output Level: 1.4V/RMS(at 1KHz THD=1%)
- Use Distance: 50m (open area)
- Antenna Connector: TNC (50 ohms impedance)
- Sensitivity: $-103\pm 3\text{dBm}$
- Operating Temperature: $-20^{\circ}\text{C}\sim+50^{\circ}\text{C}$

SC-TD Wireless Handheld Microphone

- Frequency Range: 640~690 MHz (segmented)
- Transmitter Power Supply: 2pcs AA batteries
- Transmitter Power: $\leq 10\text{mW}$
- Second Harmonic: $\geq -40\text{dBc}$
- Frequency Stability: $\pm 0.015\%$
- Battery Life: approx. 8 hours (subject to battery capacity)
- Handheld Mic Size (D*H): 53*270mm
- Handheld Mic Weight: approx. 350g

SC-TL Wireless Bodypack Transmitter

- Frequency Range: 640~690 MHz (segmented)
- Transmit Power: $\leq 10\text{mW}$
- Second Harmonic: $\geq -40\text{dBc}$
- Frequency Stability: $\pm 0.015\%$
- Spurious Rejection: $\geq 50\text{dB}$
- Power Supply: 2pcs AA batteries
- Interface Type: 3.5mm self-locking jack
- Battery Life: approx. 8 hours (subject to battery capacity)
- Bodypack Transmitter Size (L*W*H): 79*32*15.5mm
- Bodypack Transmitter Weight: approx. 100g

SC-TW Wireless Conference Microphone

- Frequency Range: 640~690 MHz (segmented)
- Transmit Power: $\leq 10\text{mW}$
- Spurious Rejection: $\geq 50\text{dB}$
- Second Harmonic: $\geq -40\text{dBc}$
- Frequency Stability: $\pm 0.015\%$
- Battery Capacity: 1000mAh 3.7Wh
- Pickup Distance: $\leq 50\text{cm}$
- Battery Life: approx. 8 hours
- Mic Size (L*W*H): 129*101*325mm
- Mic Weight: approx. 625g
- Charge Time: approx. 3hrs
- Charge Mode: 5V-12V wired, or 10W wireless

TW-C Wireless Charger

- Power Input: for charging two devices, supports mainstream adapters at 5V/2A, 5V/3A, 9V/2A or above; for charging one device, supports at least 5V/1A
- Output Power: 5W or more
- Sensing Distance: within 5mm

Note: The above data is measured by Takstar laboratory.

■ Function Descriptions

Receiver Front Panel

- ① Function Keys: for channel selection, frequency adjustment, sync, and scan.
- ② LCD Display: displays info such as sync status, frequency, and received signal level.
- ③ IR Sync Window: sends frequency parameters to transmitter when SYNC key is pressed.
- ④ Power Switch: controls internal power supply of the receiver.

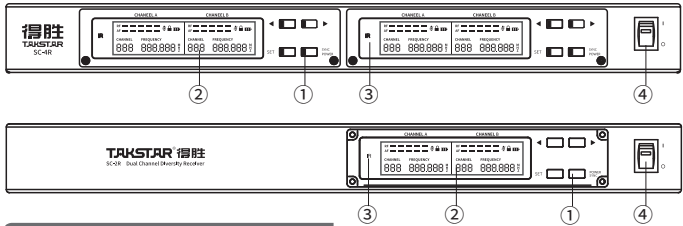

Receiver Rear Panel

- ① Power Socket: input for DC 12V power supply; the center electrode of the socket is positive.
- ② Antenna Socket: connects to external antenna to increase the distance of use.
- ③ Audio Balanced Output: XLR type socket, provides independent signal output for each channel.
- ④ Headphone Jack: used to connect headphone for monitoring.
- ⑤ Volume Control: adjusts the output volume; rotate clockwise to increase volume, or counterclockwise to decrease.
- ⑥ Mixed Input/Output: for cascading multiple devices.
- ⑦ USB Interface: used to output digital signal to an audio interface via Type-C data cable.
- ⑧ Gain Selector: used to adjust the output of MIC and LINE.

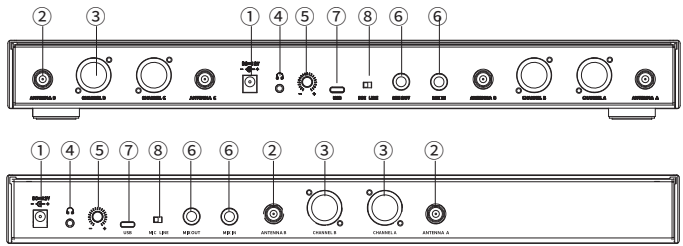

SC-TD Handheld Microphone

- ① Grille and Capsule: the grille protects the capsule which converts sound into electrical signal, and prevents the mic from rolling when placed on a surface.
- ② LCD Display: displays operating frequency, battery level.
- ③ Power: used to turn on/off the transmitter power.
- ④ Microphone Body: on the top assembles the grille and capsule, inside houses the battery, transmitting circuit board, with transmitting antenna built in at the bottom.
- ⑤ IR Sync Window: sends frequency parameters to transmitter when SET key on receiver is pressed. (IR window is inside the bottom of mic body)
- ⑥ Battery Compartment: for loading 2 pieces of AA batteries. (Please observe polarity during battery installation)

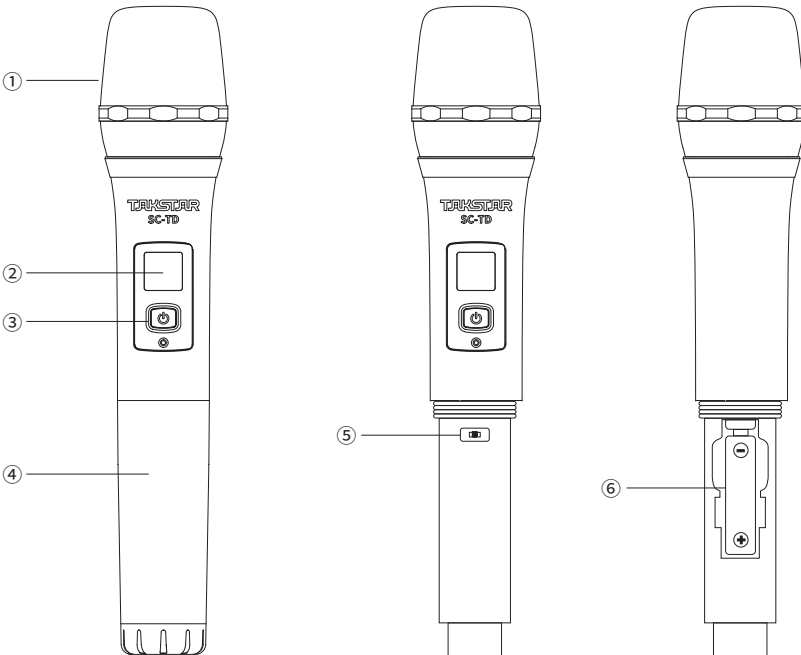

SC-TL Bodypack Transmitter

- ① Display Screen: shows info such as operating frequency and battery level.
- ② SET Key: press and hold SET to enter Gain Adjustment Mode which will auto exit after 2s of inactivity. Recommended gain level is: 4 for headset mic, and 8 for lavalier mic.
- ③ + Key: in Gain Adjustment Mode, press to increase mic gain.
- ④ - Key: in Gain Adjustment Mode, press to decrease mic gain.
- ⑤ Power/Mute Button: press and hold for 2s to power on/off, press to turn on/off the mute function.
- ⑥ Battery Compartment: for installing AA batteries.
- ⑦ Low Cut Switch: dial to “ON” position to attenuate low-frequency environmental noise below 150Hz (e.g., traffic, air conditioner and vibration noise); dial to “OFF” to restore normal sound pickup.
- ⑧ Mute Indicator: lit in solid green when mute function is off, or in solid red when on.
- ⑨ Back Clip: used to buckle the transmitter on belt or trouser.
- ⑩ Microphone Jack: for connecting a mic with a 3.5mm connector.
- ⑪ External Antenna: 1/4 wavelength antenna, used to increase signal transmission distance.
- ⑫ IR Sync Window: transmits infrared signal when syncing.

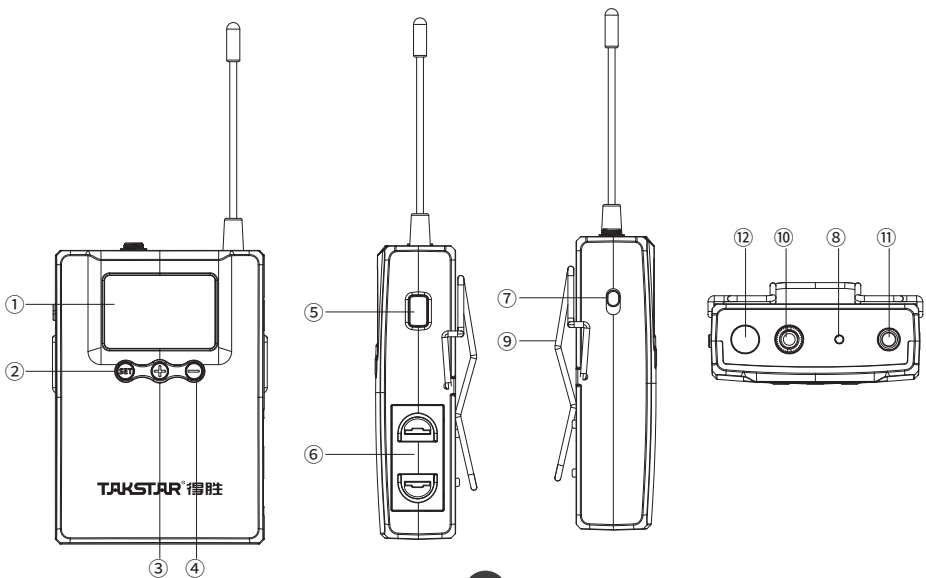

Transmitter Display

- ① Low Cut: shown/hidden when low cut is enabled/disabled.
- ② Operating Frequency: current transmitter operating frequency.
- ③ Battery Level: indicated by a bar meter; flashes when power is severely low.
- ④ Mute Indicator: shown/hidden when muted/unmuted.
- ⑤ Mic Audio Signal Meter: changes as per mic audio signal strength.

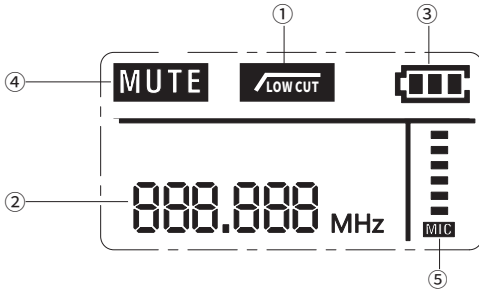

SC-TW Wireless Conference Microphone

- ① Power Button: press and hold for 2s to turn on/off mic.
- ② Mute Indicator: lit in solid blue when unmuted (enables sound pickup), or is off when muted.
- ③ Mute Switch: touch the switch to mute/unmute. Mute indicator lights up in solid blue when unmuted; touch the switch again to mute, in which case the indicator goes off.
- ④ Charging Port: charge the mic via a Type-C charging cable.
- ⑤ IR Sync Window: during sync process, point this window towards the receiver's IR window.
- ⑥ Low Cut Switch: when set to "0", mic is in normal sound pickup status; when set to "80", it filters out low-frequency environmental noise below 80Hz (e.g., breathing sound and plosives); when set to "150", it filters out low-frequency environmental noise below 150Hz (e.g., traffic, air conditioner and vibration noise).
- ⑦ High/Low Power Switch: used to switch between high and low transmitting power.
- ⑧ Gain Selector: used to manually adjust gain according to the site requirements; when the source signal is too strong, dial to "-10dB" position to attenuate to avoid distortion of the output signal; in most cases, it is recommended to dial to "0" position; when the pickup source is far away or the source signal is weak, dial to "+10dB" position to enhance the signal for clearer pickup.

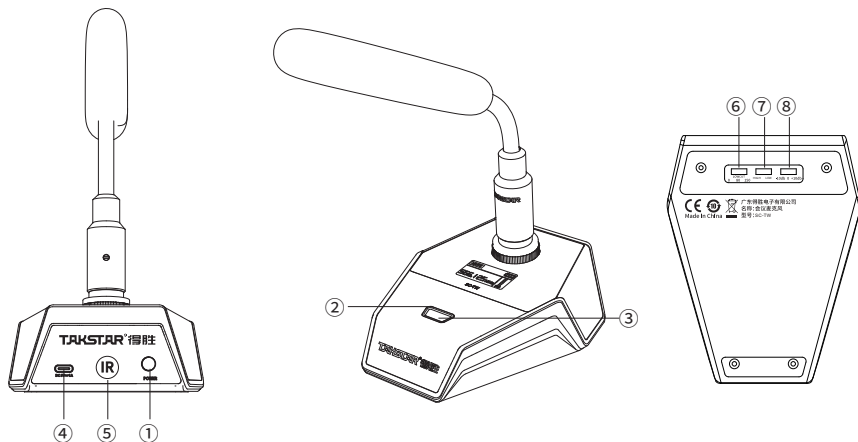

TW-C Charger

- ① Charging Port: used to supply power to the charger via a Type-C charging cable.
- ② Rechargeable Area: place the wireless mic base in this area to charge.
- ③ Indicator: lights up white when the charger is powered; breathes blue when the mic is placed for charging.

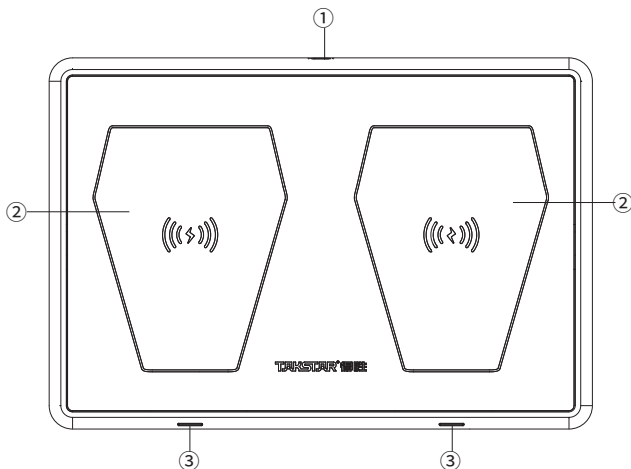

■ Operation Instructions

How to Use SC-2R/4R Receiver

Adjust Frequency

1. Manual Frequency Adjustment

First, tap SET and use ◀ or ▶ to select which channel to adjust; the display of the selected channel will flash. Next, tap SET again and use ◀ or ▶ to select a desired frequency for the selected channel. Then, tap SYNC to start syncing by aligning the IR windows of both the receiver and a powered-on transmitter (sync distance at 10~30cm). Sync is successful if the transmitter screen shows the same frequency as the receiver. In case of sync failure, the process will auto exit after 8s, please redo the aforementioned steps to retry.

2. Automatic Frequency Sweep & Sync

First, tap SET and use ◀ or ▶ to select which channel to adjust; the display of the selected channel will flash. Next, press and hold SYNC for 2s to start automatic frequency scan in the selected channel. The frequency on screen will change until a clean frequency is found, after which the receiver will automatically start IR sync, as shown below. Then, align the IR windows of both the receiver and a powered-on transmitter to sync.

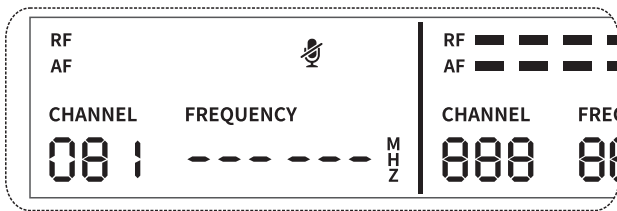

(Note: To use multiple transmitters simultaneously, the already-paired transmitters must be turned on when performing auto scan for another transmitter)

3. Volume Adjustment

First, tap SET and use ◀ or ▶ to select which channel to adjust; the display of the selected channel will flash. Then press and hold ◀ or ▶ for 2s to start volume control, tap ◀ or ▶ to select a desired volume level (9 steps from 1~9).

4. System Lock

Lock: press and hold SET for 2s in the default UI to lock all function keys (except for the power switch), the screen will change from Figure ① into Figure ②.

Unlock: press and hold SET for 2s to unlock, as shown in Figure ③.

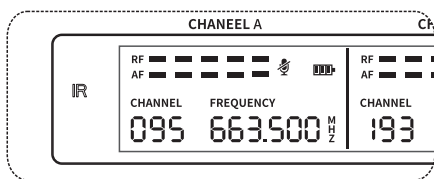

①

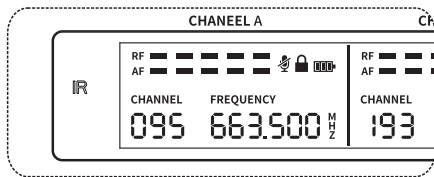

②

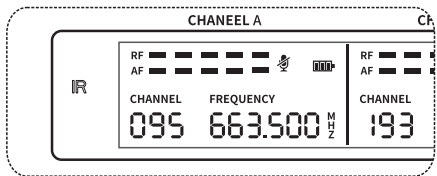

③

How to Use SC-TD Handheld Microphone

1. Install two AA batteries into battery holder in correct direction. Press and hold power button for about 2s, the LCD display will light up, and the mic will power up, as shown below. The LCD screen also shows the current operating channel and battery level.
2. To change the operating channel, you should change the receiver channel first, then align the IR windows of both the transmitter and the receiver, and press SYNC on the receiver panel to send the new channel parameters to the transmitter (please refer to the Adjust Frequency section for receiver instructions).
3. To turn off the mic, press and hold power button for about 2s until the display shows "OFF" and goes off.

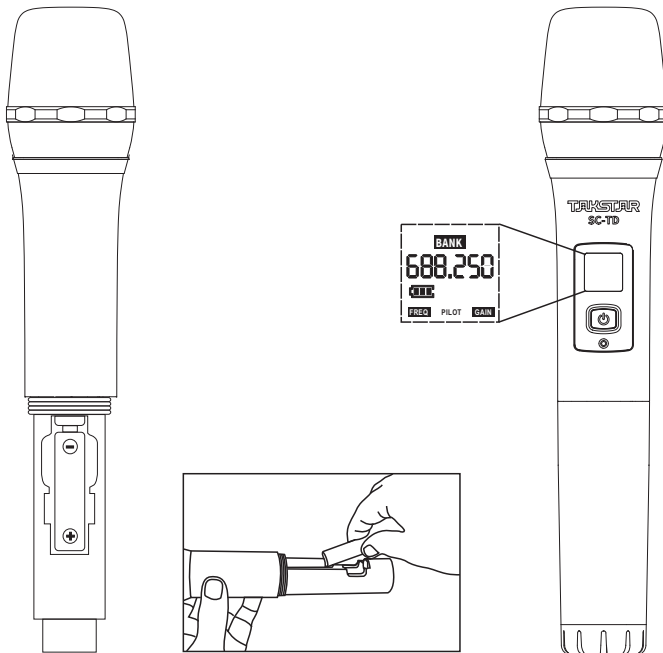

How to Use SC-TL Bodypack Transmitter

1. Install batteries: push both the retractable buttons on the battery compartment to remove it. Install 2 pieces of AA batteries according to the polarity directions marked on the battery holder. Then insert the battery holder into the battery compartment until you hear a click sound, as shown in Figure A.
2. Insert the headset mic or lavalier mic plug into the transmitter's MIC socket and lock it in place, as shown in Figure B.
3. Turn down the receiver volume before powering on, then turn on the receiver by pressing the receiver power switch. Once powered on, the receiver LCD backlight lights up and then shows the receiver channel, frequency and auto sync status.
4. Observe the RF and AF level meter on receiver LCD. Change channel to avoid interference frequency if necessary.
5. Press and hold the transmitter power button for 2s to power on. The receiver RF level meter of the corresponding channel should increase.
6. To change the operating channel, you should change the receiver channel first, then align the IR windows of both the transmitter and the receiver, and press SYNC on the receiver panel to send the new channel parameters to the transmitter (please refer to the Adjust Frequency section for receiver instructions).
7. Adjust the receiver's mic output volume level as appropriate.

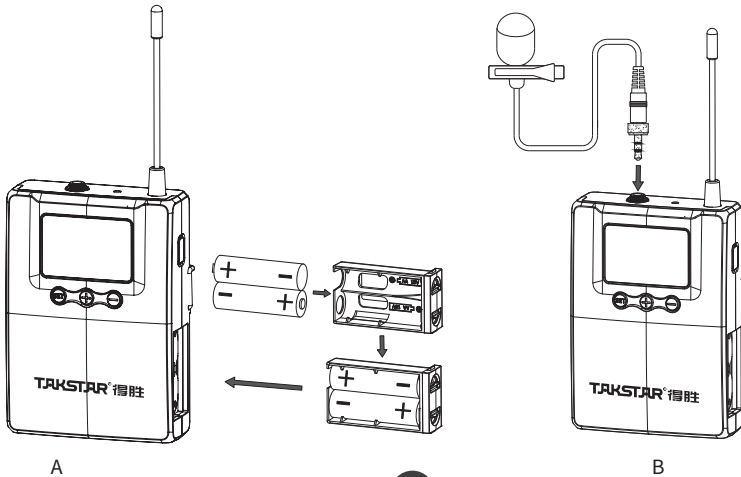

How to Use SC-TW Wireless Conference Microphone

1. Press and hold the power button for 2s to turn on the mic.
2. To change the operating channel, you should change the receiver channel first, then align the IR windows of both the transmitter and the receiver, and press SYNC on the receiver panel to send the new channel parameters to the transmitter (please refer to the Adjust Frequency section for receiver instructions).
3. Touch the mute switch to unmute, in which case the indicator lights up blue.
4. Recommended distance from the mic is about 20-50cm when speaking.

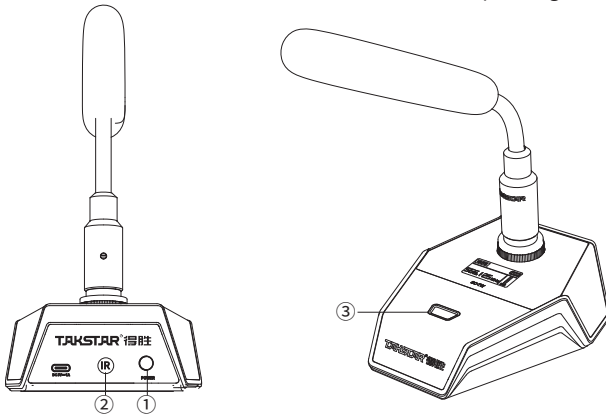

How to Use TW-C Charger

1. Connect the wireless charger with a compatible power adapter or USB power bank via the supplied USB cable.
2. Ensure that the wireless charger is facing upright without any objects on top.
3. Place the wireless conference mic in the rechargeable area specified on the charger. The indicator flashes blue while charging.

Note: If placed incorrectly, the wireless conference mic may not charge properly.

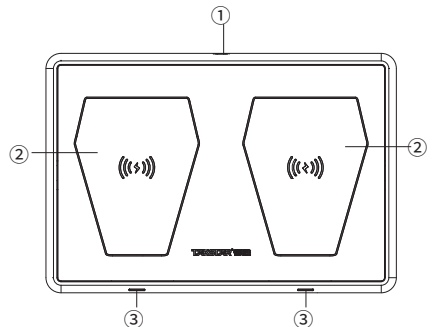

■ Troubleshooting

Issue	Cause
No response on transmitter or receiver screen.	Transmitter battery is dead; receiver power supply is not properly connected.
No RF signal on receiver.	Different frequency between transmitter and receiver; or out of effective range.
Has RF signal but no AF.	Transmitter is muted.
Loud background noise in audio signal.	Low output level on receiver; there is interference signal; receiver antennas are not installed, lowering S/N ratio.
Audio signal distortion.	Transmitter frequency deviation is too high; or receiver output level is too high.
Short operating distance, unstable signal.	Receiver antennas are not properly installed; or there is strong electromagnetic interference around.

■ Safety Instructions

To avoid electric shock, overheat, fire, radiation, explosion, mechanical risk and injury or property loss due to improper use, please read and observe the following items before use:

1. Please check if the power of the connected equipment matches with that of this product before operation. Adjust the volume to proper level during operation. Do not operate at over-power or high-volume level for extended time to avoid product malfunction or hearing impairment.
2. If there is any abnormality during use (e.g., smoke, strange odor), please kill the power switch and unplug from power source, then send the product to the local dealer for repair.
3. Never use any replacement battery with broken insulation. Do not charge non-chargeable battery.
4. Dispose waste batteries in designated dustbin for sorting. Do not use them as children's toy nor discard directly to avoid health risk or environmental damage.
5. Keep this product and its accessories in a dry and ventilated area. Do not store in a humid or dusty area for extended time. Keep away from fire, rain, liquid intrusion, bumping, throwing, vibrating, or from blocking any ventilation openings, to prevent malfunction.

6. The product must, when installed on walls or ceilings, be fixed firmly in place at adequate strength to prevent from falling.
7. Please abide by safety rules during operation. Do not use the product in places prohibited by laws or regulations to avoid accident.
8. Do not disassemble or repair the product by yourself to avoid injury. If you have any questions or require any services, please contact our local dealer.

■ About This Manual

This manual contains up-to-date technical specifications as of printing. However, specifications contained herein may not conform to your particular product since Takstar is constantly improving its products. For the latest version/more information, please visit our website: <https://www.takstar.com/>

Specifications, devices or accessories available may vary from region to region. If you have any questions, please contact our local dealer.

注意事项：

1. 本单为保修凭证，请用户妥善保管，如有遗失，恕不保修或退换。
2. 保修期限制：购买之日起十二个月内。
3. 除了不可抗力事件损坏外，由本公司负责，免费维修。
4. 如属保管不善或使用不当造成的损坏，维修点将酌情收费。
5. 擅自拆卸维修者，不予保修。
6. 以上保修条款仅限于中国市场适用（不含港澳台地区）。

产品服务保证书

姓名：_____ 电话：_____ 地址：_____

商品：_____ 型号：_____ 购买日期：_____ 年 ____ 月 ____ 日

维修记录栏 (由维修员填写)	维修员签名	日期

◆广东得胜电子有限公司 ◆电话：400-6828-333 ◆地址：广东省惠州市博罗县龙溪街道富康一路2号



扫一扫，了解更多产品
Scan for more
product information

广东省电声工程技术研究开发中心 广东得胜电子有限公司制造

地址：广东省惠州市博罗县龙溪街道富康一路2号

服务热线：400 6828 333 传真：0752 6383950

邮箱：xs@takstar.com

网址：www.takstar.com

Guangdong Takstar Electronic Co., Ltd.

Address: No. 2 Fu Kang Yi Rd., Longxi Boluo

Huizhou, Guangdong 516121 China

Tel: 86 752 6383644 Fax: 86 752 6383952

Email: sales@takstar.com

Website: www.takstar.com